

DEFINITIONS

Linear

- Motors
- Resistive heaters
- Incandescent lights

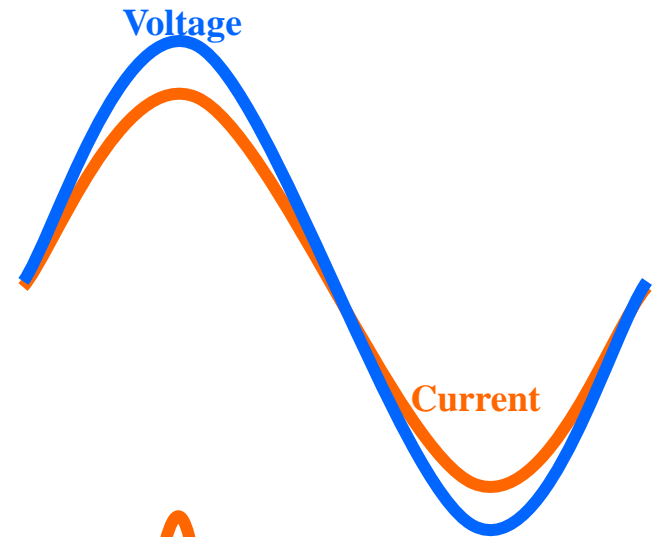

Non-Linear

- Computers
- VFD's
- Electronic loads

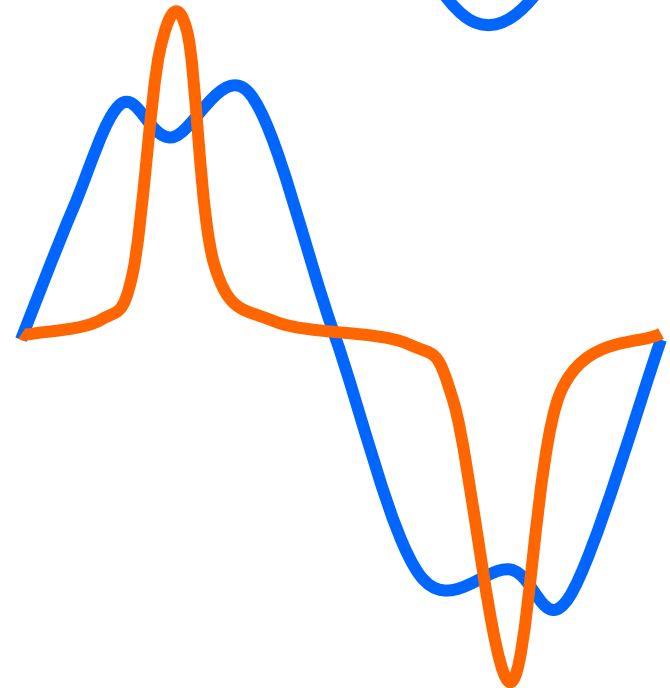

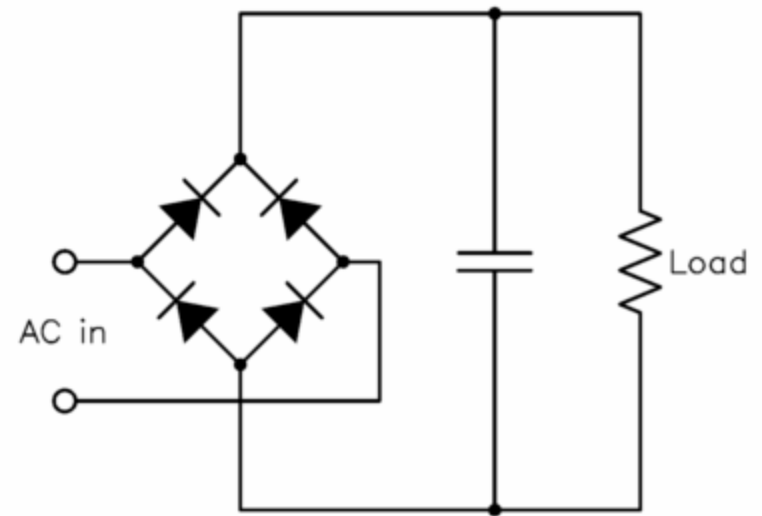
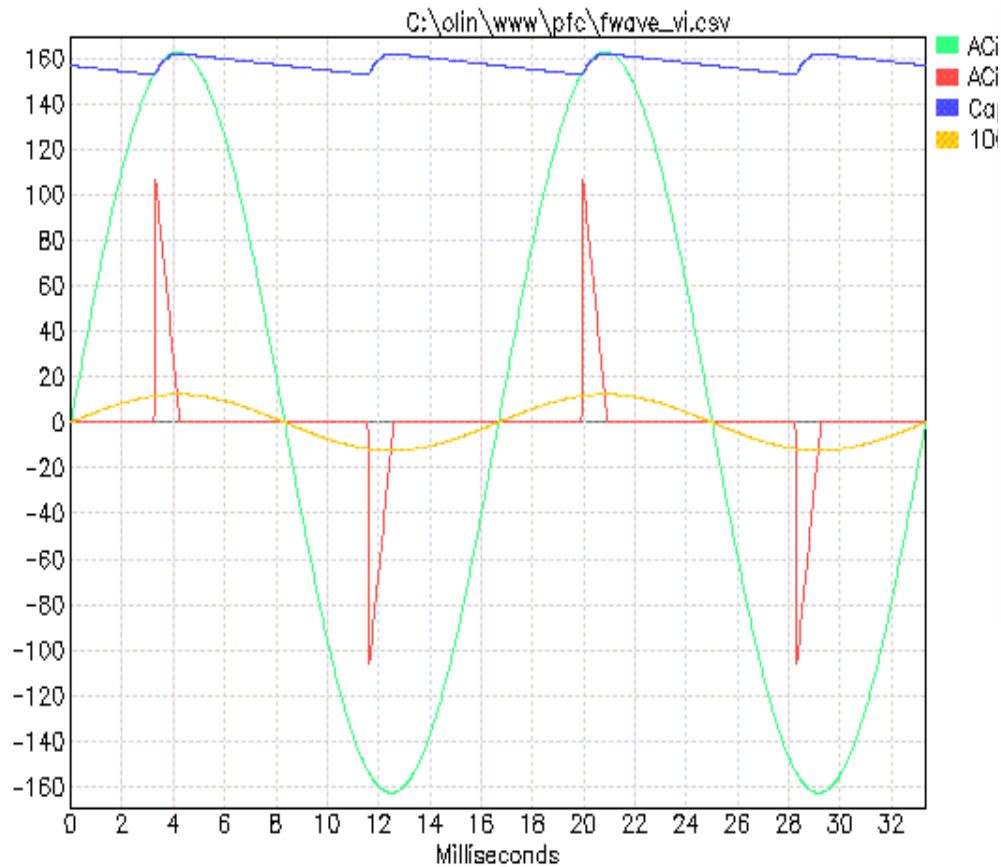
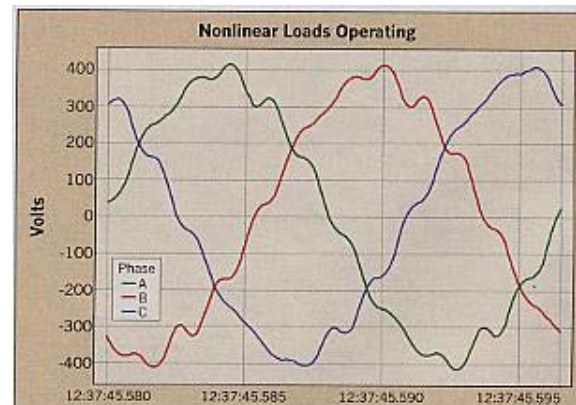
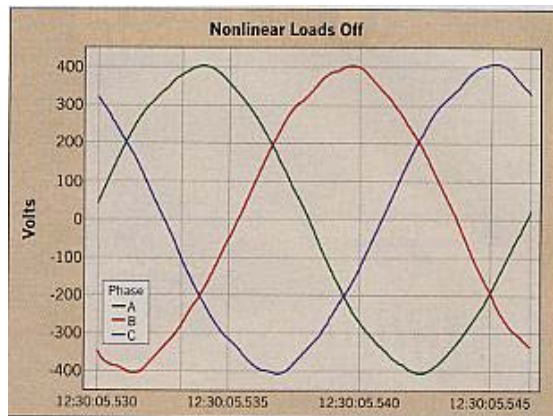
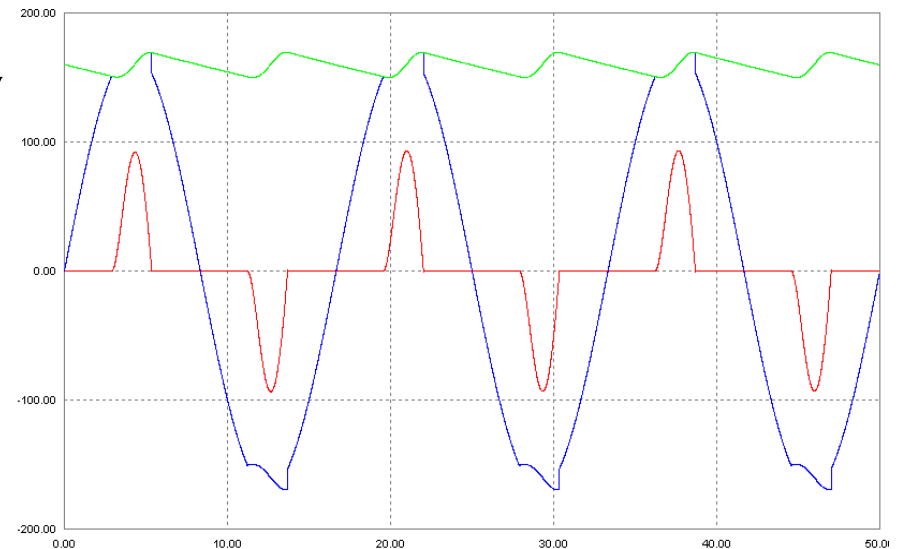
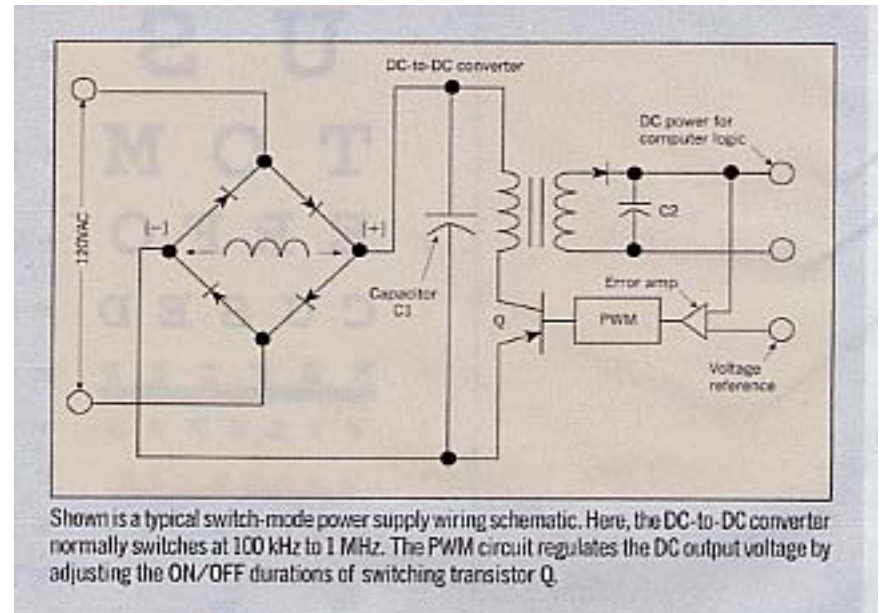

Figure 1



SMPS

- Diodes rectify the input AC to produce DC for HF converter
- Current flows only when the input AC wave is higher than the DC (~ 20% of period) recharging DC bus
- Current waveform does not follow voltage (non-linear)
- Waveforms shown are V_{in} , I_{in} and V_{dc} . Note:
 - Current flows only when $V_{in} > V_{dc}$ causing spiking
 - Input Voltage distortion caused by current draw only at peak AC in



Nonlinear Loads

3 - phase Loads

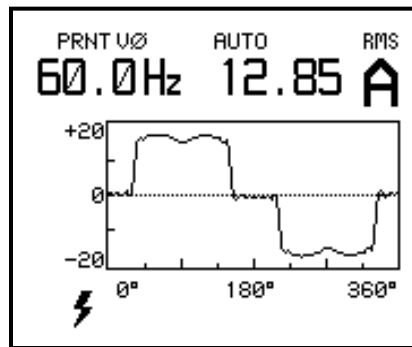

1 - phase Loads

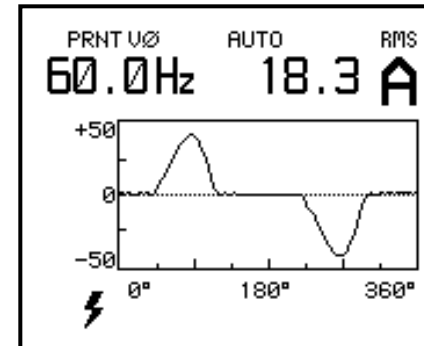

Harmonics 101

Harmonics are multiples of the fundamental frequency that when added to the fundamental component regenerate the original waveform

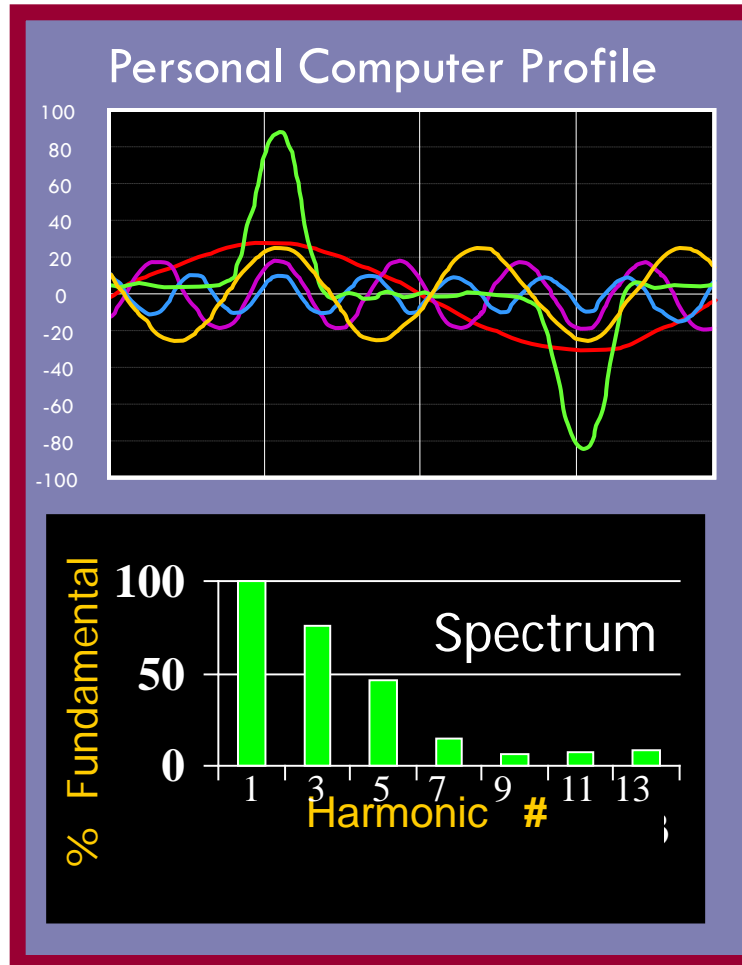

Fundamental

3rd

5th

7th

HARMONIC CURRENT CONTRIBUTIONS

Load description	Harmonic Order							
	1	3	5	7	9	11	13	15
Six-pulse rectifier	100	—	17	11	—	5	3	—
Twelve-pulse rectifier	100	—	3	2	—	5	3	—
Eighteen-pulse rectifier	100	—	3	2	—	1	0.5	—
Twenty-four pulse rectifier	100	—	3	2	—	1	0.5	—
Electronic/computer	100	56	33	11	5	4	2	1
Lighting/electronic	100	18	15	8	3	2	1	0.5
Office with PCs	100	51	28	9	6	4	2	2
VFD's (range)	100	1 to 9	40 to 65	17 to 41	1 to 9	4 to 8	3 to 8	0 to 2

Consequences of Harmonics

- *Voltage Distortion*
- *Lower Power Factor*
- *High 'shared neutral' current*
- *High Neutral to Ground Voltage*
- *Reduced Reliability of equipment*
- *High losses in distribution system*
- *Increased cooling load*

EC&M December 1988 Article

DOUBLE THE NEUTRAL AND DERATE THE TRANSFORMER—OR ELSE!

Arthur Freund, Senior Editor

CBEMA has issued an information letter explaining critical power problems from computer and electronic loads, with drastic recommendations to prevent damage to the distribution system.

COMPUTER AND BUSINESS Equipment Manufacturers Association (CBEMA, pronounced "seebeemah") is the electronic business equipment industry equivalent of the electrical industry National Electrical Manufacturers Association (NEMA). CBEMA became aware that the proliferation of switching-mode power supplies for computers and business equipment was resulting in large harmonic currents, and that these harmonics were causing severe and increasing problems in electrical distribution systems and equipment. (See "Nonlinear loads mean trouble" in *EC&M*, March, 1988). John Roberts, Manager of Corporate Power Standards for IBM, is chairman of the Power Subcommittee of the Environment and Safety Subcommittee of CBEMA. This subcommittee studied the problem and possible solutions, and CBEMA has issued an



3rd Harmonic Currents in L1, L2, L3 and N

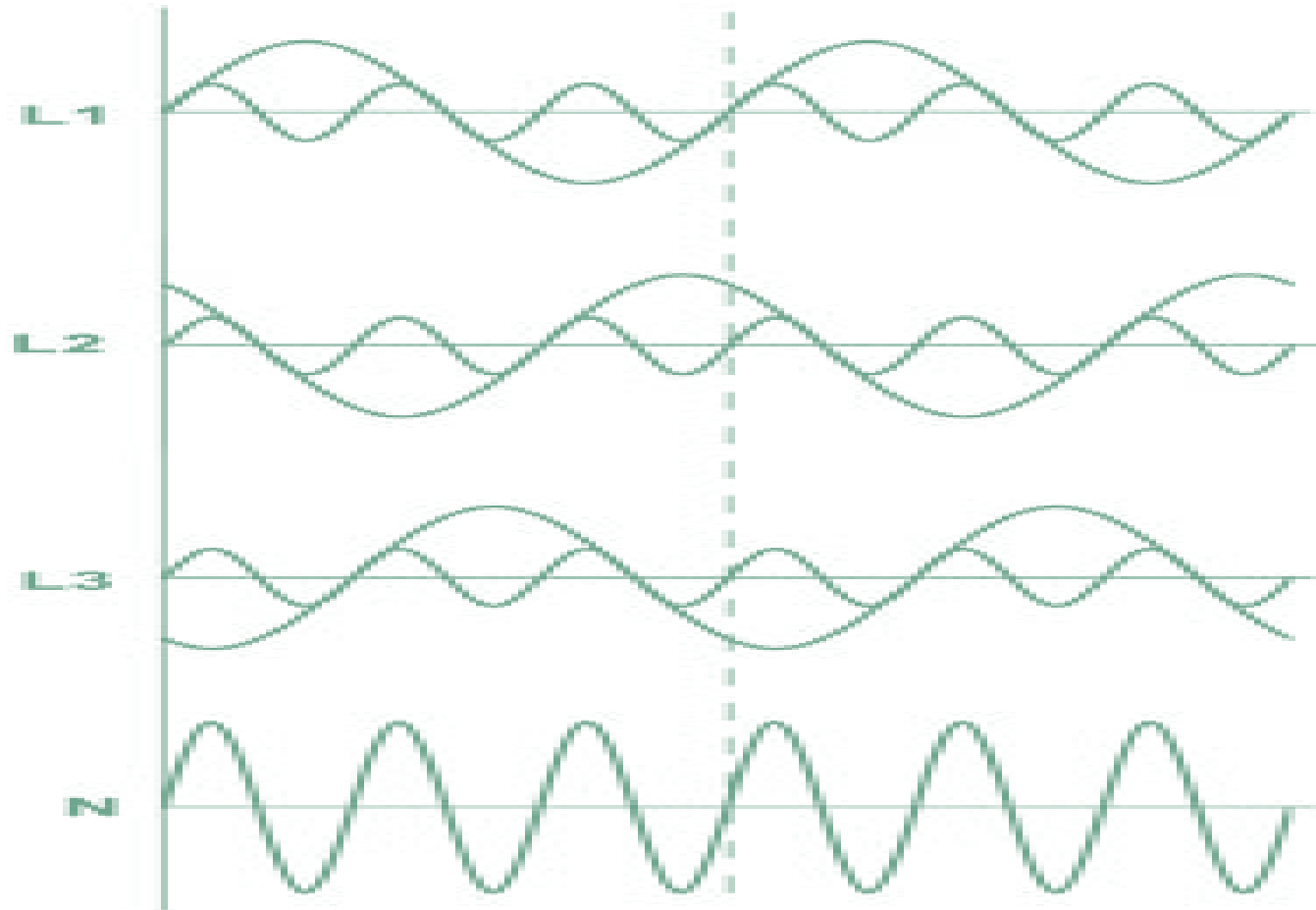

Loss of Capacity



TRANSFORMER CAPACITY (%)
AFTER DERATING FOR
ELECTRONIC LOAD

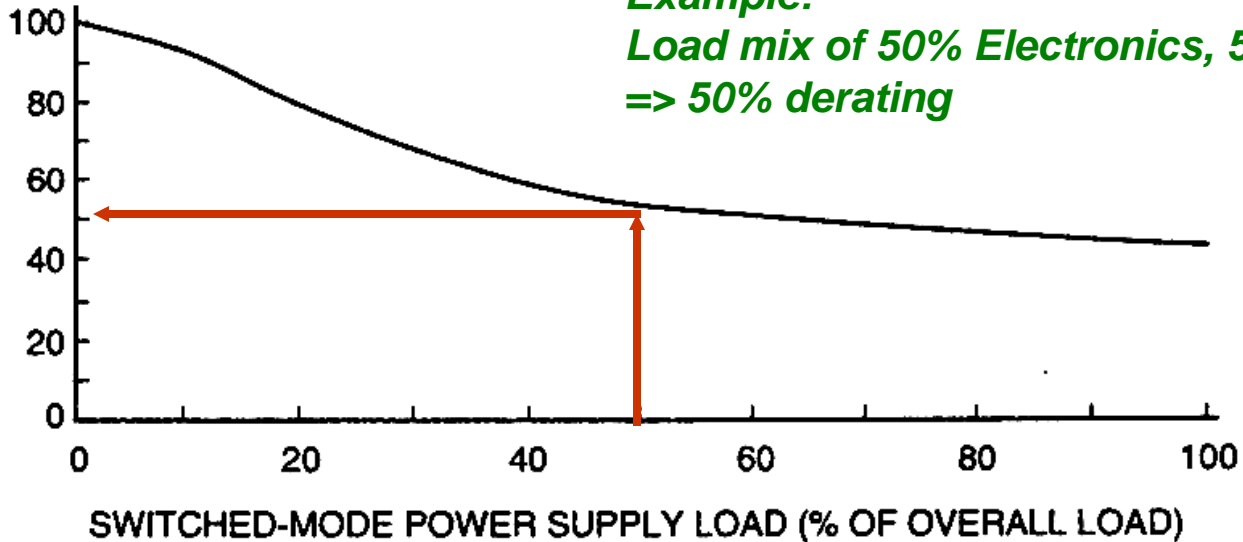

*Example:
Load mix of 50% Electronics, 50% linear
=> 50% derating*

Source: Based on [B4].

Fig 9-11
Transformer Capability for Supplying Electronic Loads

Reference: IEEE-1100 Standard "The Emerald Book"

Transformer Options

- Industry reacts to harmonic and energy issues with a mix of transformer products:
 - Standard (Derated conventional delta-wye)
 - K-rated
 - TP-1
 - Harmonic Mitigating

NEMA TP1 EFFICIENCY

- NEMA Standard Publication TP1-2002,
- CSA Publication C802.2-00 and
- EPA Energy Star® requires NEMA TP1 compliance.

These standards exclude harmonic mitigating transformers feeding non-linear loads.

Most TP 1 transformers can't achieve their nameplate efficiency rating if connected to real world non-linear loads.

Harmonic mitigating products should exceed TP 1 efficiencies for both linear and non-linear loads.

Rating kVA	Eff. %
15	97.0
30	97.5
45	97.7
75	98.0
112.5	98.2
150	98.3
225	98.5
300	98.6
500	98.7
750	98.8
1000	98.8

Table 'A'
NEMA TP1-2002
35% FL Requirements

Single Phase Harmonic Flow

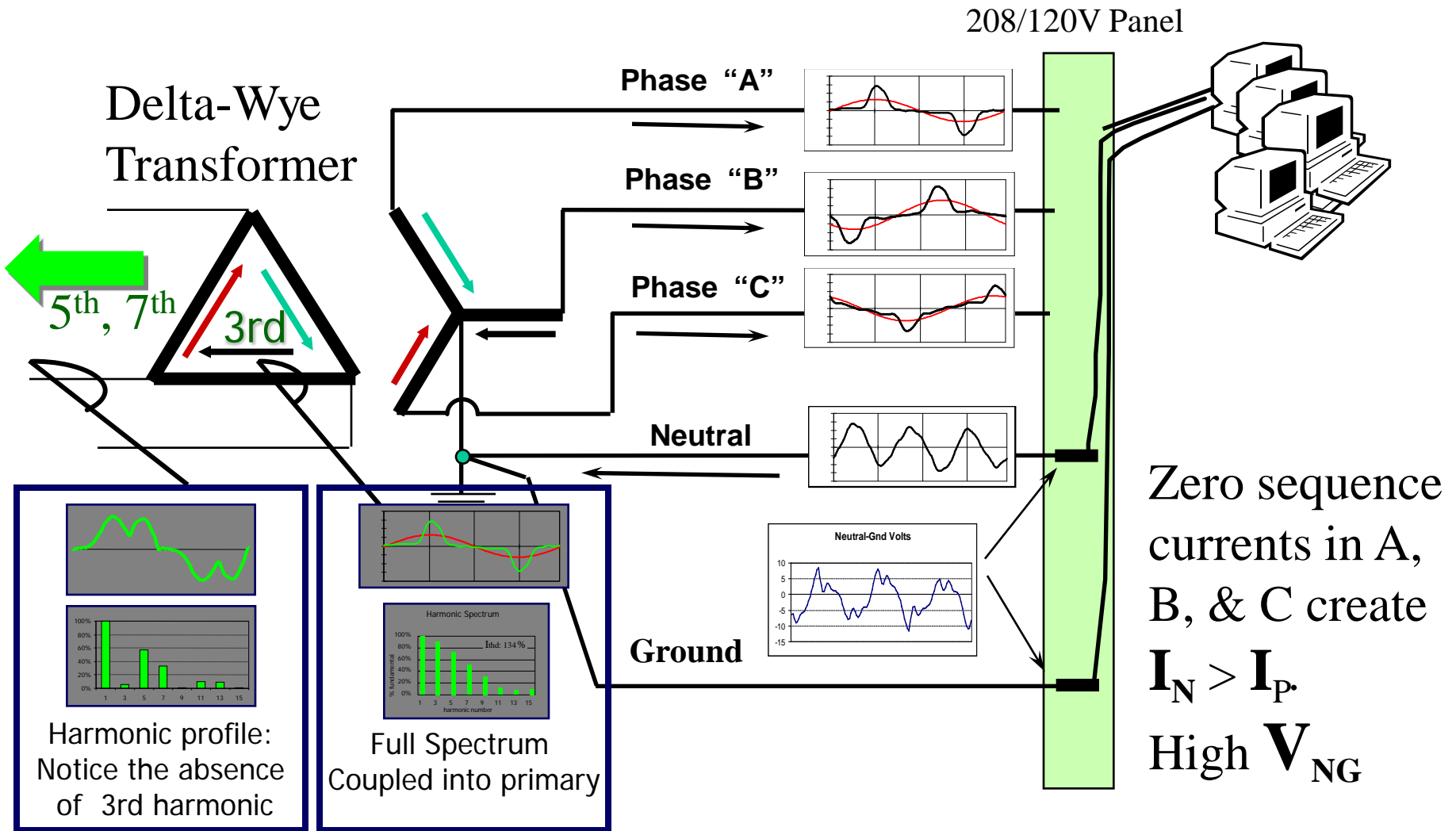

Transformer Losses

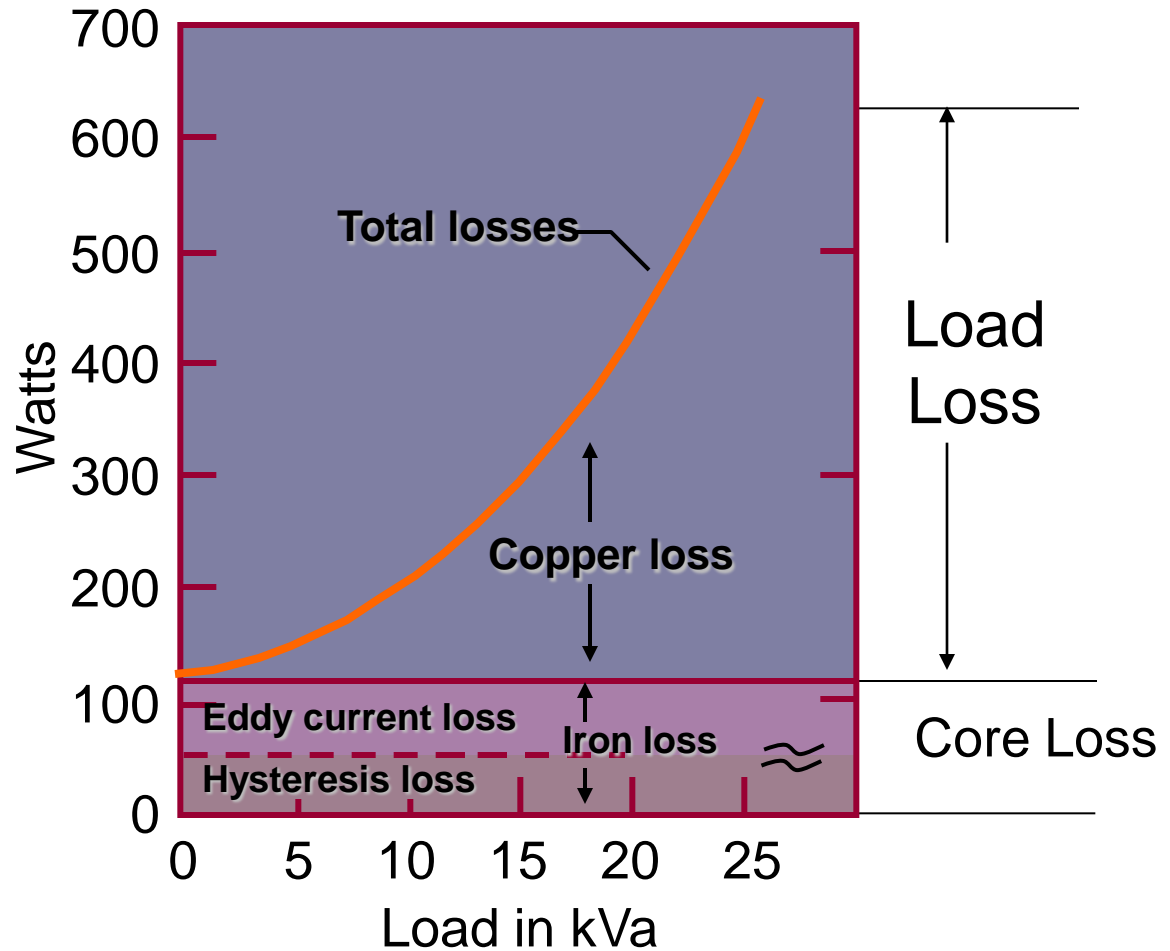
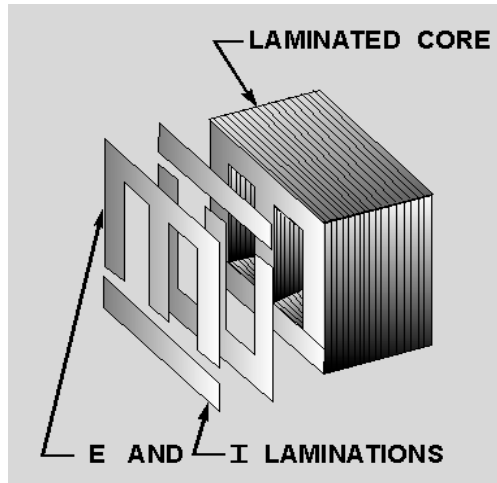
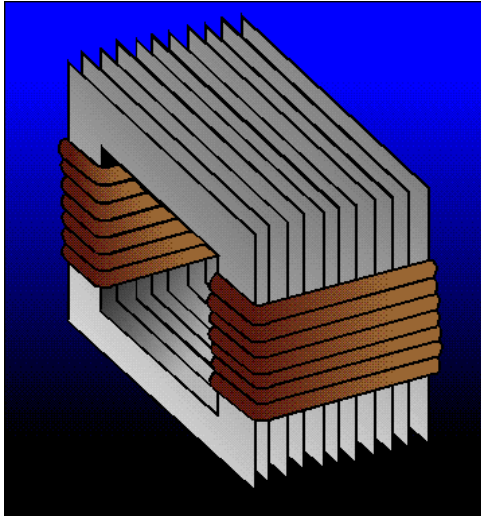

Losses versus load, (Courtesy of EPRI.)

Transformer Losses

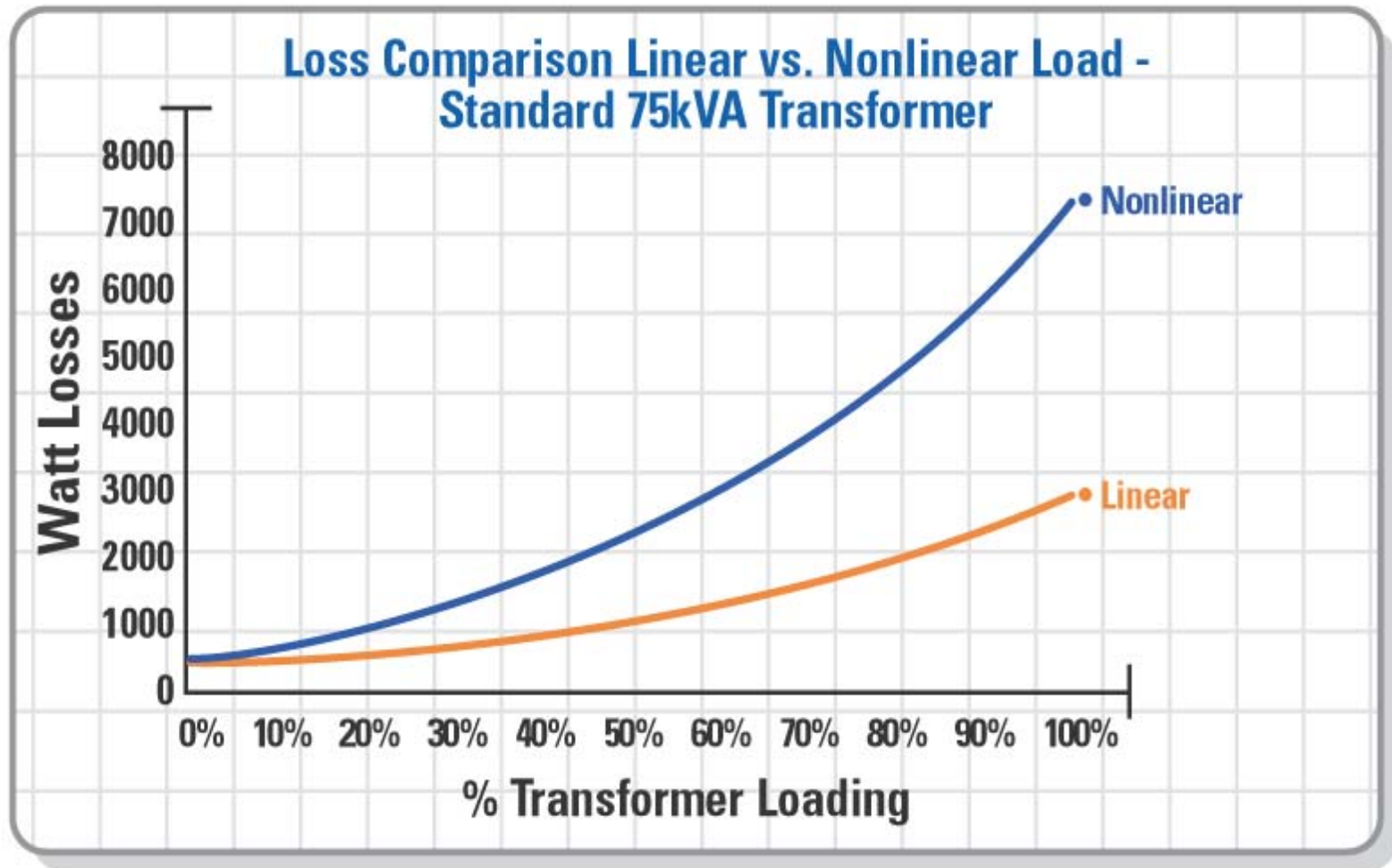

HMT Efficiency vs. Typical 112.5kVA Transformer

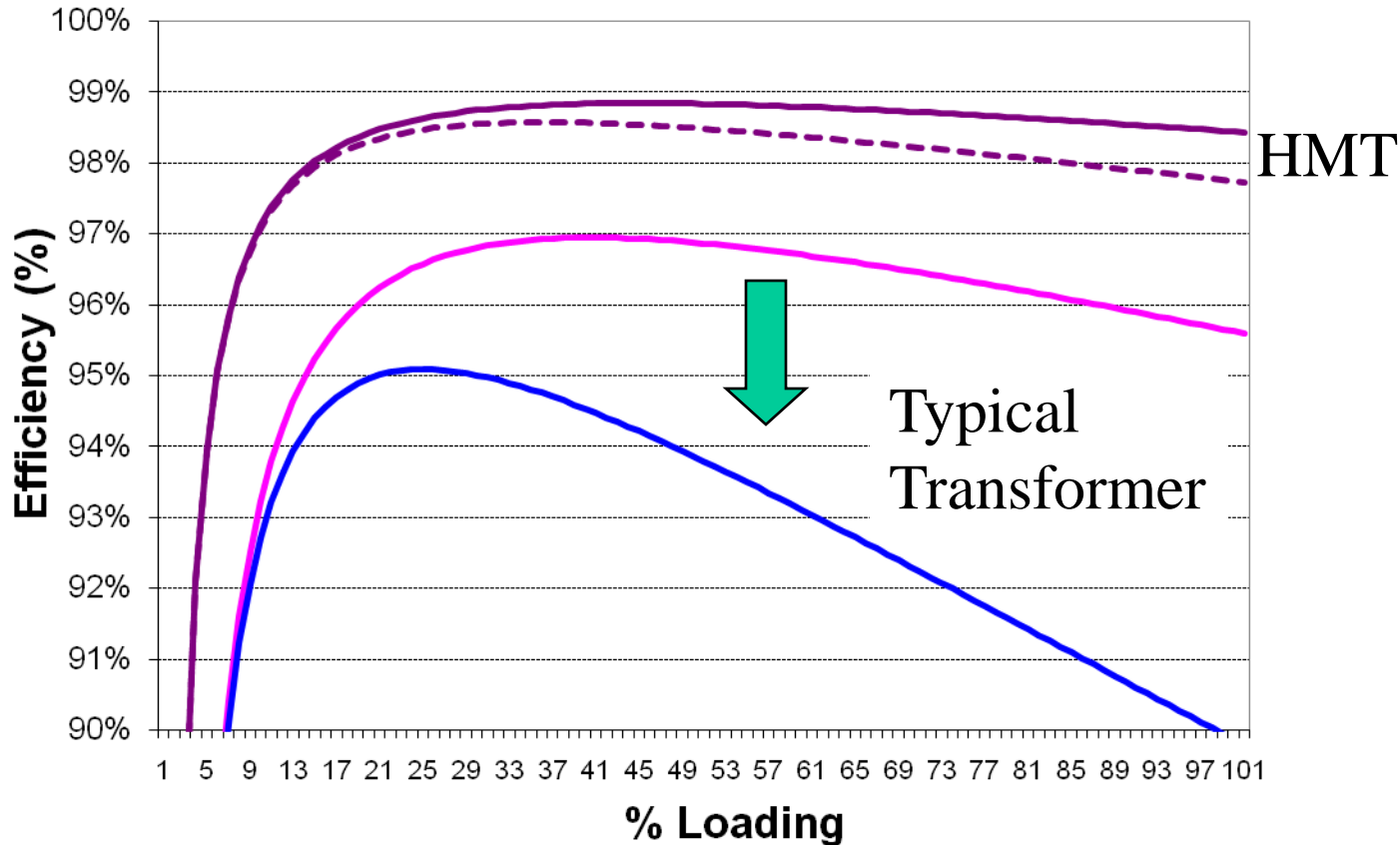

HMTs consistently higher efficiency

Typical Transformer is significantly lower under linear and electronic load

Transformer Loss Data

Table VI

Transformer T_1 Harmonic-Related Losses and Cost Per Year

Load = 60 kW 3-phase, on 112 kVA	P_{loss} (W)	Cost/Year
Copper loss = $\sum I_h^2 R$	2986	\$1,308
Eddy current loss $P_{EC} = \sum I_h^2 h^2$	1336	\$585
Total load loss $P_{LL} = \sum I_h^2 R + P_{EC}$	4322	\$1,893
Base load loss = $1.05 \times I^2 R$	1575	\$690
Penalty = $P_{LL} - 1.05 \times I^2 R$	2747	\$1203

IEEE Transactions on Industry Applications, Sept/Oct. '96
 "Costs and Benefits of Harmonic Current Reduction for Switch-Mode Power Supplies in a Commercial Office Building"

Tom Key, PEAC
 Jih-Sheng Lai, Oak Ridge National Lab, Lockheed Martin Energy Research

K-Rating = Factory Derating

The Product

- Larger core, larger conductors and/or multiple conductors, larger air ducts
- More winding layers, shorter coil height, larger enclosure and more weight

The Consequences

- *harmonic currents still flow in primary and secondary*
- *higher no-load losses*
- *increased costs*
- *excessive voltage distortion*
- *Larger footprint*

$$K = \sum_{h=1}^{h=h_{\max}} I_h^2 h^2$$

I_h = rms current at harmonic h ,
in per unit of rated rms load current

Survival at Best – K-Rating is not the Answer

Harmonic Mitigation Technology

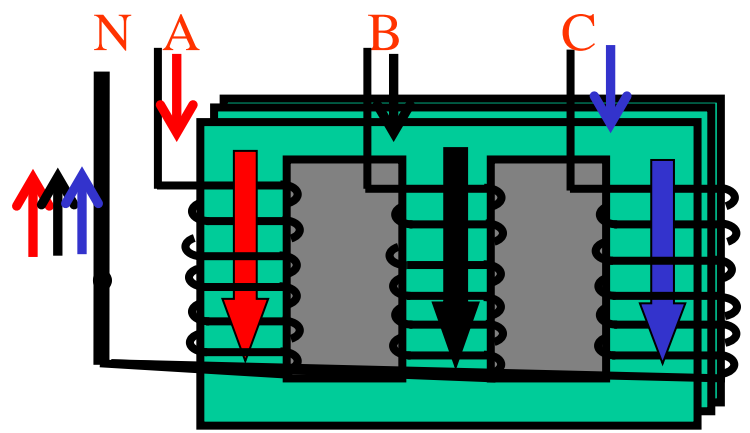

Typical Delta-Wye Connections

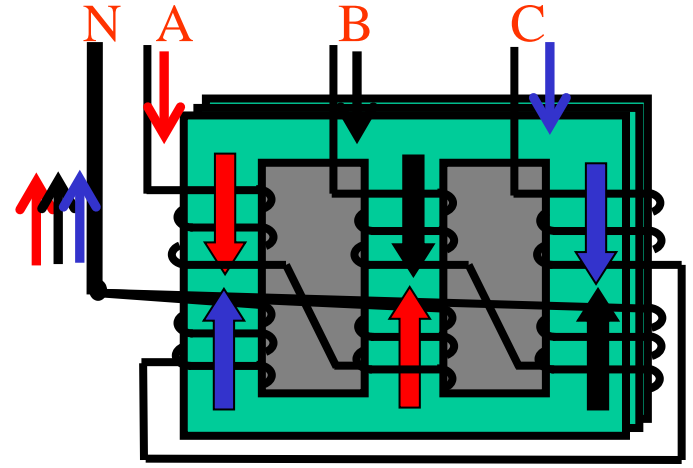
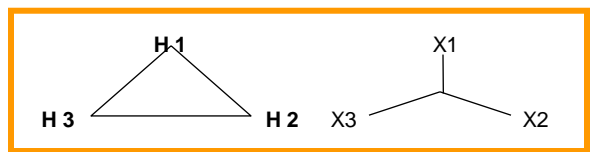
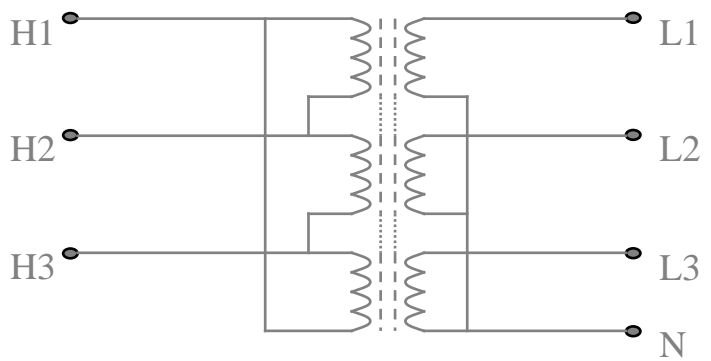

Typical PQI Type DV Connections

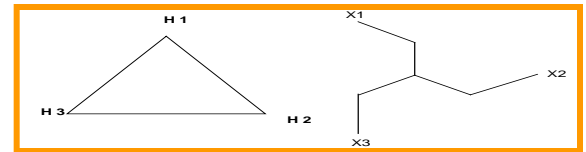
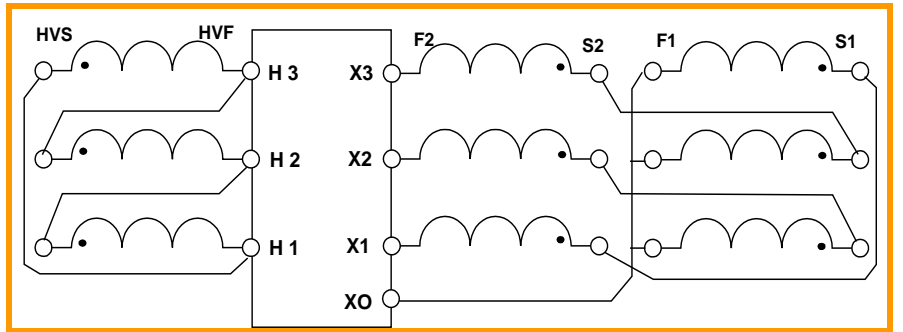

CONVENTIONAL CORE

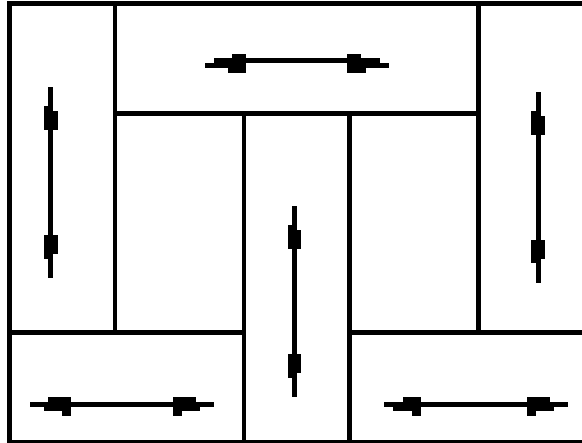

A conventional transformer's butt lap cut core consists of rectangular sheets of core steel arranged in such a way that the grain orientation of the steel is along the flux path, except in the corners where the flux path changes direction from the legs to the yoke members.

HMT CORE

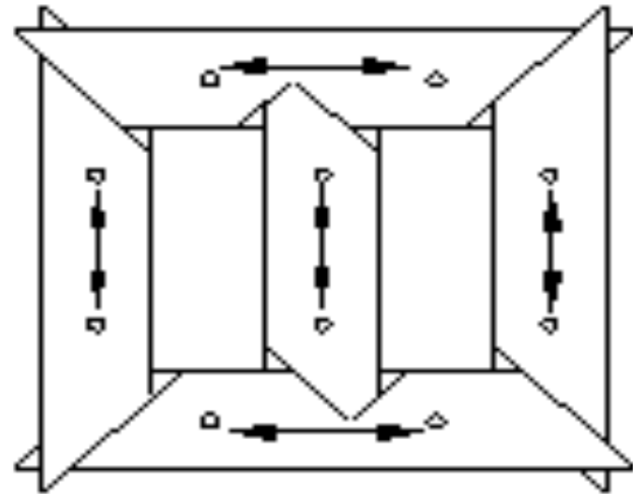

The HMT transformer's full and step lap mitre cut core ensures that the overlapping of the joints in the corners are mitered and staggered so that the best possible grain orientation and flux transition is achieved. This design reduces core loss.

FLUX CANCELLATION

- 3rd is in phase in all 3 phases
- 2 half coils in each leg
- Flux cancellation in each leg
- Low zero sequence impedance
- Attractive alternate path for triplens

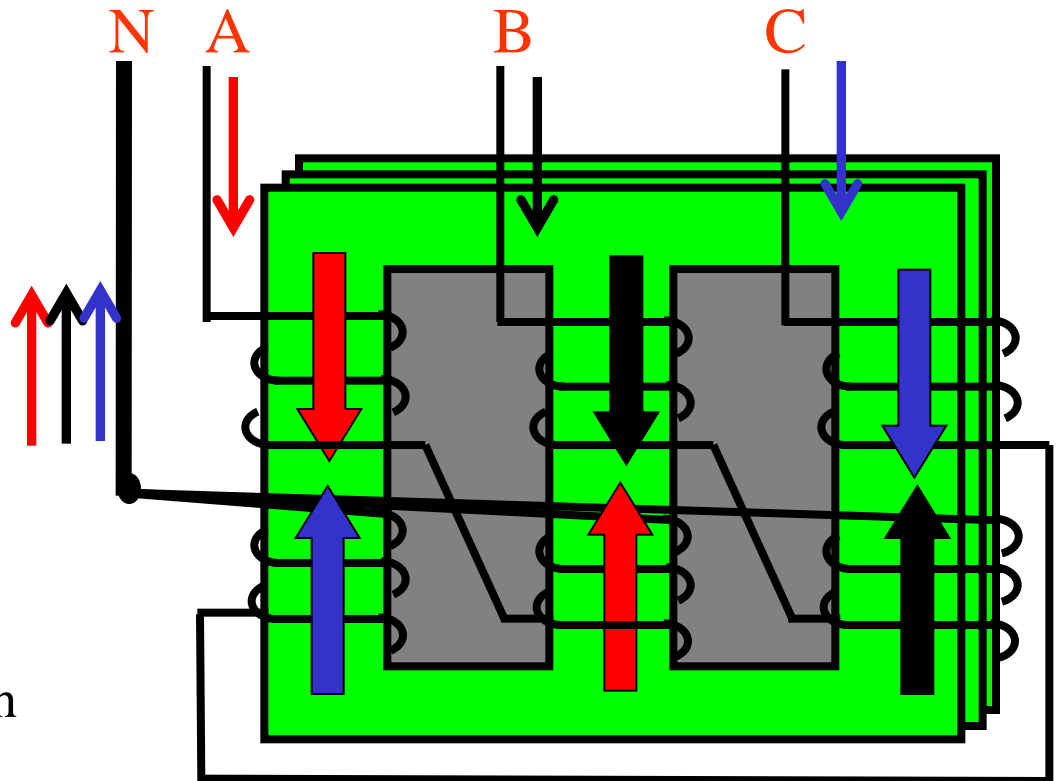

LINEAR vs NON-LINEAR LOSSES

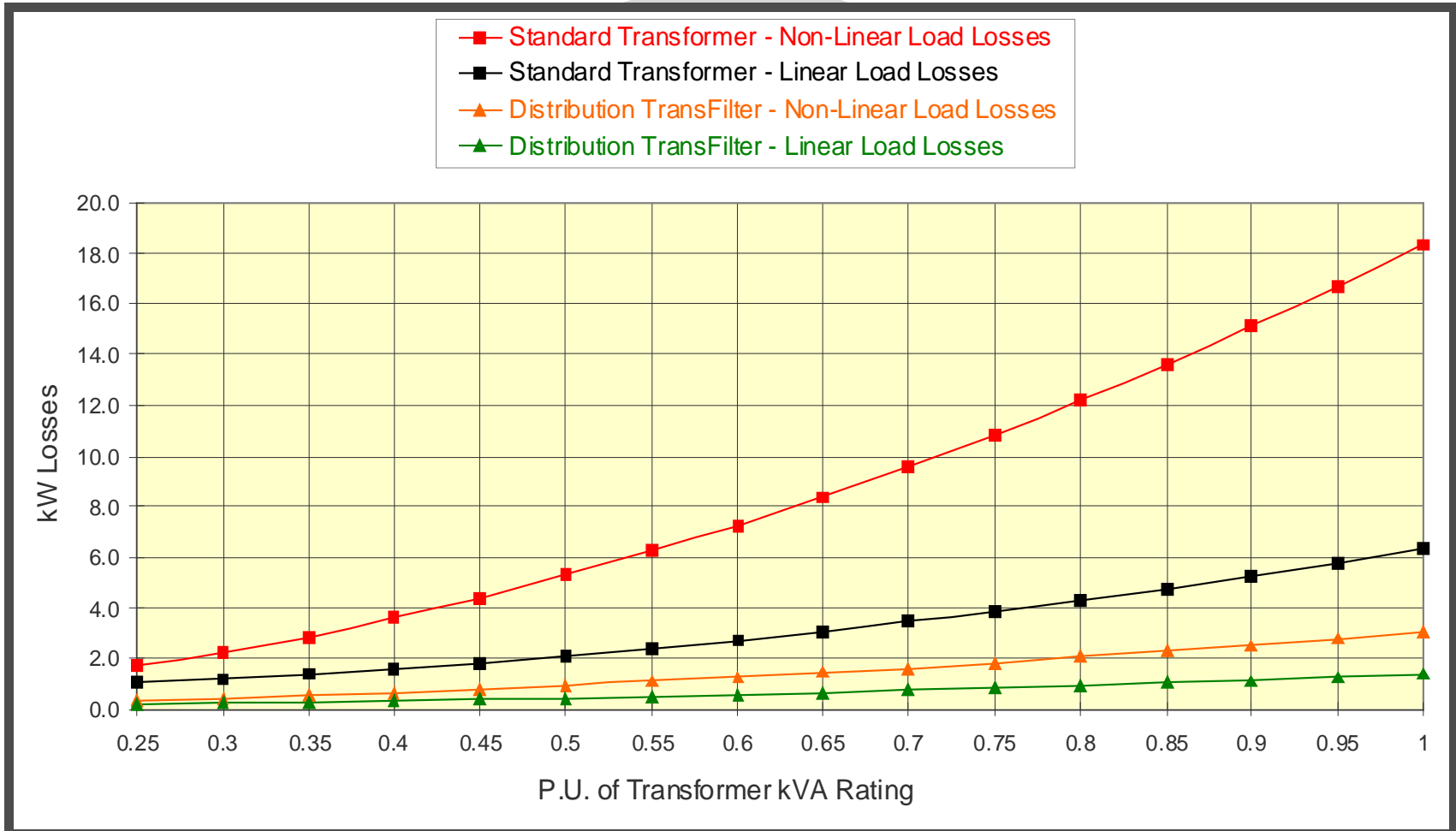

75kVA Conventional Transformer vs. 75kVA High Efficiency, Harmonic Mitigating Transformer

HMT TRANSFORMERS

- Reduces voltage flat-topping caused by electronic loads
- Lower operating temperatures – reduced cooling
- Harmonic currents do not circulate in primary winding
- Saves energy by reducing losses created by harmonics
- Enhances equipment life-span by reducing distortion
- Maintains very high efficiency under severe electronic loads
- Reduces distortion at UPS, generator or utility service
- Exceeds NEMA TP-1 and meets IEEE 519 limits
- Improves upstream total power factor
- Mitigates harmonics – benefit not achieved by k-rated xfmrs

First Costs Versus Life Cycle Costs

- *“...make sure that products put into our facilities have the most effective life-cycle cost. You’re going to pay more upfront, but in the long run you are going to save money.”*
- *Carl Larson, President of Washington State Association of Maintenance & Operations Administrators.
American School & University, January 2006 issue.*
- *Life cycle costing encourages return on investment analysis and better decision making*
- *First cost versus ongoing savings*
- *Energy Savings Calculator*

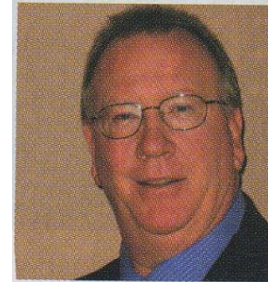

Savings

- Conventional Transformer efficiency drops from 95% to as low as 85%
- HMTs efficiency 98%+

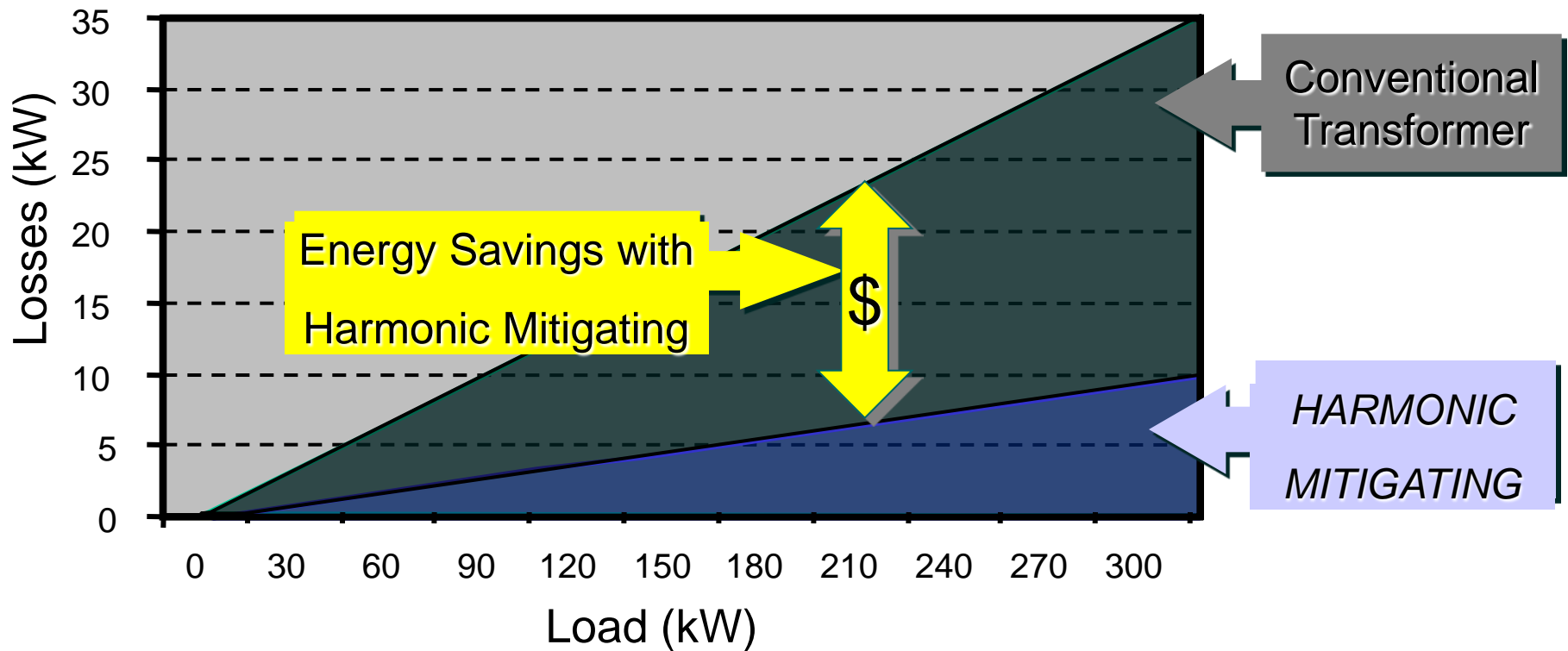

Savings Over Lifespan of Transformer

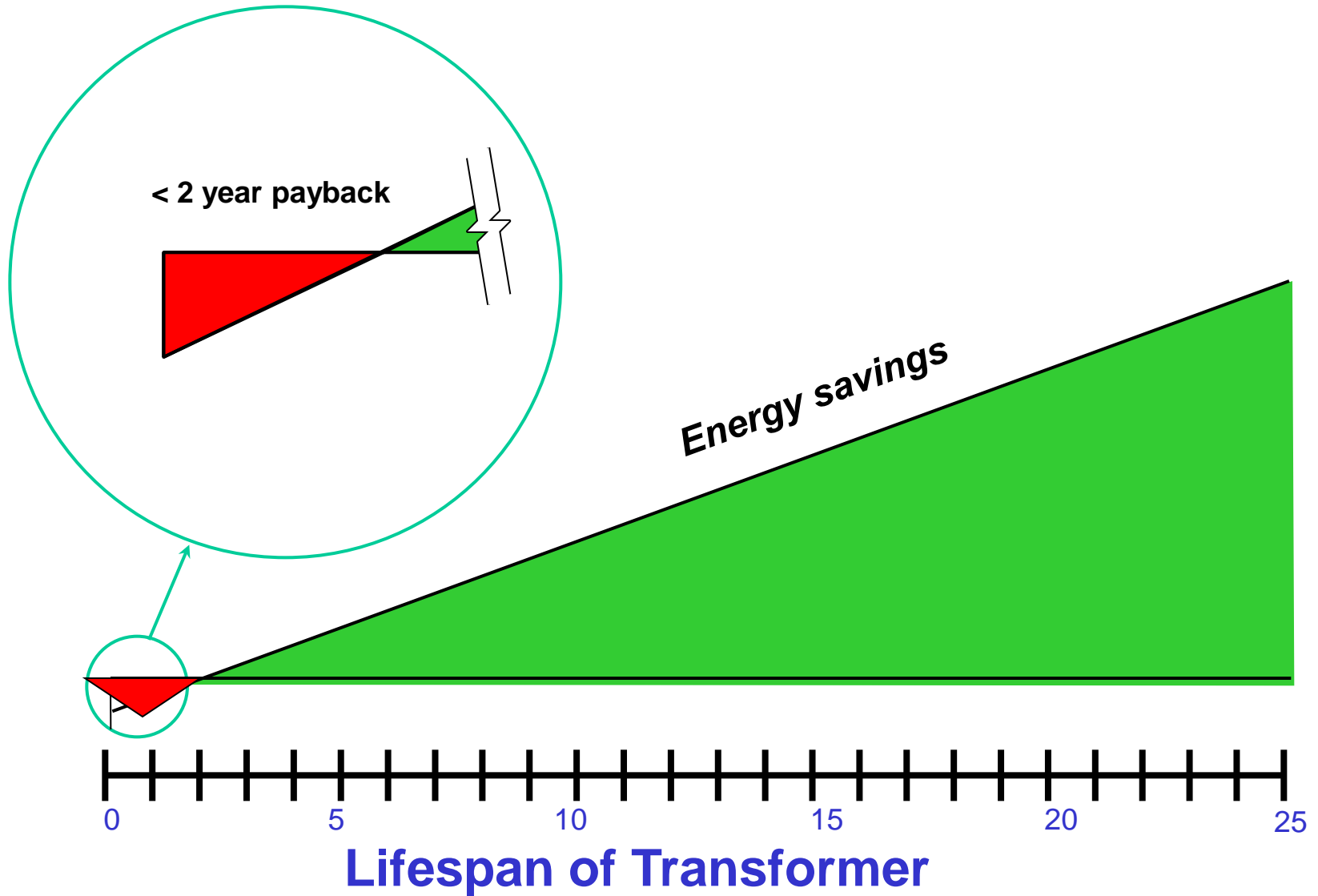

Life Cycle Costing

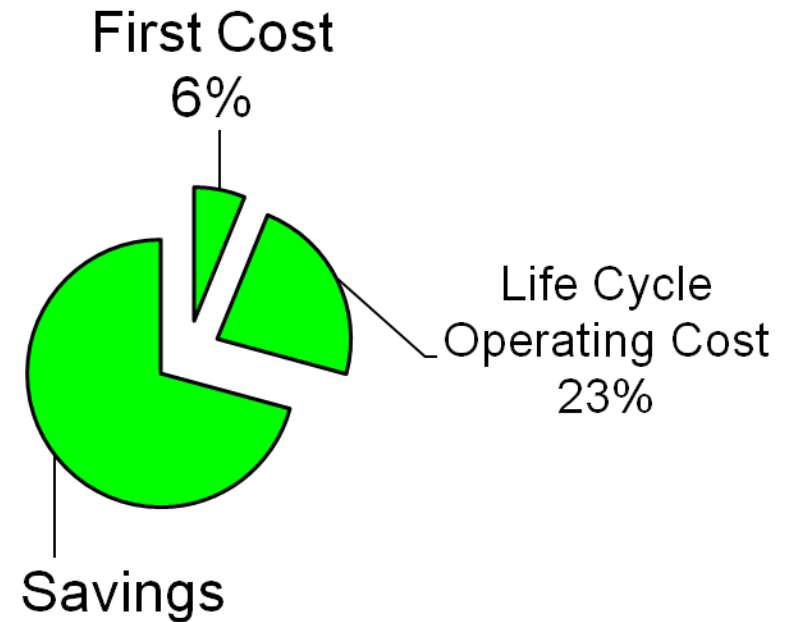
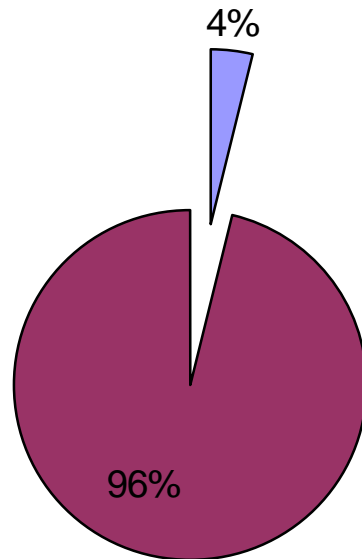

Financial Benefits

- *Lower transformer losses*
- *Reduces system losses*
- *Improved power factor*
- *Better equipment reliability*
- *Less maintenance costs*
- *Longer equipment lifespan*
- *Acceptable ROI*

***HMT Transformers provide savings
year after year***